

# 'TECHNICAL SHORTS'

by Gerry O'Hara, G8GUH

**'TECHNICAL SHORTS' is a series of (fairly) short articles prepared for the Eddystone User Group (EUG) website, each focussing on a technical issue of relevance in repairing, restoring or using Eddystone valve radios. However, much of the content is also applicable to non-Eddystone valve receivers. The articles are the author's personal opinion, based on his experience and are meant to be of interest or help to the novice or hobbyist – they are not meant to be a definitive or exhaustive treatise on the topic under discussion.... References are provided for those wishing to explore the subjects discussed in more depth. The author encourages feedback and discussion on any topic covered through the EUG forum.**

## Receiver Alignment

### Introduction

Much has been written on aligning receivers (or 're-aligning', assuming that the receiver in question was aligned to start with!) and I am sure many folks reading this will have plenty of experience of doing this – if so, apologies. However, I am also sure that many Eddystone enthusiasts with little experience of re-alignment will have had to try to undo the best efforts of someone who had no clue (or, dangerously, only a bit of a clue) of what they were doing – at worst, this can range from someone 'tightening up all those loose screw-thingies that crumble to dust when a bit too much effort is applied to the screwdriver' - Aaarghhh!, or who did not have even the most basic of test equipment or information on the receiver being worked on (the 'mad twiddler' syndrome...). Having been shown how to align a receiver by 'little John' at my job in a radio repair shop circa 1971, I was eager to try out my new-found skill in those dim and distant days of my youth, so one of my first experiences of re-alignment was with my Eddystone EC10 (I must have done it a hundred times trying to squeeze the last ounce of performance out of the poor thing) – unfortunately its IF transformers were not really up to this amount of adjustment and I remember replacing at least one of them and all the iron dust cores...

This 'Short' is really meant for those 'casual' radio 'techs' that may need to do this procedure once in a blue moon, but when they do, they want to do it right (and they cannot remember quite how



My happy box of alignment tricks...

they did it the last time), though I think others may pick up a tip or two also: a receiver is nothing if not aligned properly, and in the case of our favourite marque (and in the words of the EUG 'wise old men'), "a deaf Eddystone is a sick Eddystone", and the sickness may, or may not, be a result of poor alignment (or at least in part). This article deals with aligning HF (broadcast and shortwave) AM/SSB/CW receivers, however, all the general information provided is also useful for lower/higher frequency and/or FM receivers. However, I do not discuss alignment of FM detector circuits herein (eg. Foster-Seeley discriminator and Ratio Detectors), as this is covered in a separate 'Short' on 'Detectors'.

### What is 'Alignment' Anyway?

With the exception of early tuned radio frequency (TRF) receivers, almost all radio receivers employ a single tuning dial – it is therefore essential that all the tuned circuits that it controls resonate simultaneously at the same frequency (or by a fixed offset to it), ie. they must be 'aligned'. In practice, such alignment for the RF circuits consists of making compensatory adjustments to the circuits to account for small discrepancies in their physical construction or electromagnetic loading on them during the tuning process: the measure of success in undertaking this process is often gauged by how well the receiver 'tracks', or holds both its frequency calibration (against the dial markings) and sensitivity/selectivity across the tuning range(s). In the case of superheterodyne (superhet) receivers, alignment of the local oscillator(s) (LO) and IF stages are also critical to obtaining optimum receiver performance.

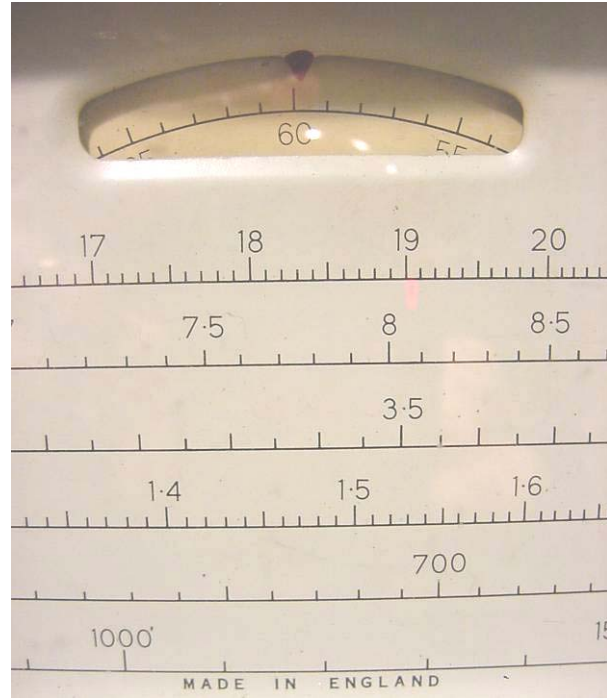

### Why do Receivers Lose Their Alignment?

All commercially-available receivers are aligned when new by their manufacturers: Eddystone in particular took great pains to ensure accurate calibration before their sets departed the 'Bath Tub' for the big wide world – the pride in this is testified by comments in the contemporary advertising literature (though I am sure that no one there had an inkling that many of the sets would still be in service after 5 decades or more!). The factory-set alignment would, for quality receivers such as Eddystone, hold for many years, as the components used in the tuned circuits were selected for stability and reliability: high quality, solidly-constructed mechanical parts, such as the main tuning gang, IF transformers and, in the case of post WWII Eddystone valve sets, the infamous diecast metal coilbox, together with carefully designed circuits and layouts. In addition, passive components were purposely selected by Eddystone for their stability under a wide

range of temperature and humidity conditions and only top-tier valves were fitted (usually Mullard).

So, with all the above precautions, why do Eddystones (or other sets) ever need to be re-aligned? – well, there are a number of reasons for this, which manifest in symptoms such as instability, de-tuning or loss of efficiency ('Q') of tuned circuits, mainly due to physical changes in the components over time (ie 'ageing'), caused by temperature and humidity cycling, electrical effects (eg. over-voltage due to another failed component), poor component design/construction (eg. dielectric type or sealing problems), dust or other foreign matter (eg. wax from paper capacitors or oil/WD40 from over-enthusiastic lubrication of dial drive mechanisms), changing a valve, where the replacement may have different inter-electrode capacitance or other characteristics that affect the loading on the associated tuned circuits, changing a passive component in a tuned circuit, or even just re-dressing the component leads (though the latter should not be too much of an issue below 20MHz or so). The result is one or more of poor sensitivity (possibly even to the point of no stations being received), poor selectivity, incorrect dial reading of the tuned frequency (or the same station appearing more than once on the tuning range), or instability (oscillation where it should not be – giving howls, squeals or rushing noises).

A mistake often made by the inexperienced radio enthusiast (aka. 'former owner') that possesses that 'oh-so-dangerous level of knowledge', ie. is sufficient to be aware that poor-alignment may cause 'deafness' or other 'misbehaviour' of a receiver, but is insufficiently experienced or knowledgeable to be able to diagnose other faults that may also have caused or contributed to the problem: the age-related issues noted above usually occur over many years and any change more sudden than this is much more likely to be a failed (or failing) component(s). In some cases, the 'problem' may start out as being caused by something 'silly' such as the IF gain control being turned down inadvertently and the set suddenly appearing 'deaf' - then the random 'tweaking' starts to try to rectify the (non) problem and before you know it the set is hopelessly out of alignment for no reason other than ignorance and/or 'digital paralysis'.

### **When Should Re-Alignment be Done?**

Assuming that the usual set of receiver checks have been undertaken (see the 'Short' on receiver fault finding), that all receiver stages are working within their normal DC operating parameters and that no component problems are present, then there is definitely a case for checking the alignment. Other symptoms that would indicate re-alignment may be appropriate include:

- if the receiver is functioning well (is sensitive and selective) but the dial accuracy is poor on one or more Bands;
- the receiver output varies or distortion is noted when tuning across a signal (likely an IF alignment issue);
- some Bands appear to 'work' better than others;
- the same station can be heard at more than one location on the dial;

- a single station (or stations) seem to be spread over a large part of a Band or overlay each other;
- the receiver does not 'track' correctly across the tuning range on one or more bands;
- the receiver sensitivity appears to vary across the tuning range on one or more bands.

Some tuning-related issues, such as drifting or frequency 'jumping' cannot be cured by re-alignment – the causes of these faults, while related to the tuned circuits, are due to physical changes to the components or connections between them and should be investigated with standard servicing procedures prior to considering re-alignment.

### Alignment Equipment and Tools

An entire tomb could be written on the equipment needed for the re-alignment of a receiver (or that is simply 'useful' – there is a difference). The main items needed for basic AM/SSB/CW re-alignment procedures are:

- **Signal Generator(s):** Whilst some crude re-tuning (not really alignment) can be undertaken using received signals, especially when stations of known frequency can be heard (only if the receiver is not too far out of alignment), the lack of known signals across all bands and at all times of the day/night when you may be doing the work, fading and other 'on-air' effects make this far from ideal and therefore a good signal generator (genny) covering the IF and RF range of frequencies of interest is really a 'must have': standard 'service-quality' signal generators can be bought for a few tens of dollars on EBay or new ones for not much more. I use a typical valve-based 1950's service-grade 'genny' manufactured by Triplet, Model 3432-A, bought on EBay for around \$80. It covers 160kHz through 220MHz (plus more on harmonics), has variable AM modulation, a fairly basic output attenuator and is remarkably stable after 30 minutes or so. I also have a Superior Inst. Model 660-A that is not as nice to use (or as stable), but extends down to just below 100kHz. For lower frequencies (eg the 85kHz second IF found in the S.750), I use a Heathkit 'audio'



generator (Model IG-5218) that covers all frequencies up to 100kHz. Also needed is an appropriate cable, with croc clips at the receiver end, and a few isolating capacitors - 0.1uF for IF stages and 0.01uf (or lower) for RF stage injection.

- **Output Meter:** Many novices think that they can tune a signal peak by 'ear', well yes, you can, but it is surprising what an improvement can be made using a visual aid. I use a Triplet multimeter (Model 630-NA) that has an 'output meter' input – circled on the photo, right - (it simply has an internal 0.1uf capacitor that is connected in series with the AC voltage ranges): if your multimeter does not have this facility, just connect a capacitor externally. While the receiver S-meter (if fitted) can be used for peaking receiver tuned circuits, it has the disadvantage that it is not sensitive to signal level changes at very low levels and it may be connected into the circuit ahead of the final IF transformer (many Eddystones are like this: the S-meter is located in a bridge circuit connected to the screen grid of the final IF stage, thus adjusting the cores of the final IF transformer will have little or no effect on the S-meter reading. A simple output meter can be made using a milliammeter and a couple of components (see Lighthouse articles).

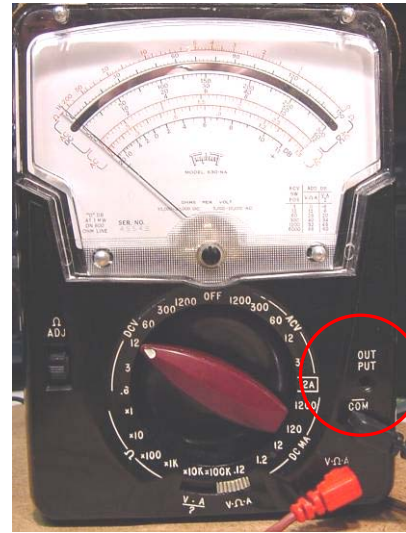

The above essential instruments can be supplemented with:

- A crystal-controlled 'marker' oscillator: this instrument is very useful when the receiver local oscillator alignment is 'way out'. I use a homebrew unit I made when I

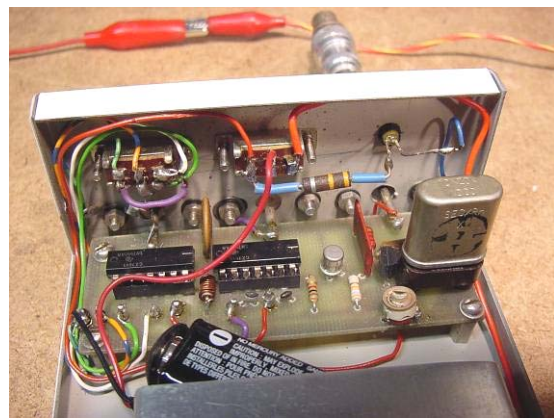

was 16 (I think it was in 'Practical Wireless') that has switchable 1MHz, 100kHz, 12.5kHz and 10kHz output markers set up using one of the standard frequency transmissions on 10MHz or 15MHz (see photo above). I also used to use a 'Class-D' Wavemeter and a

BC221, but these still reside in my mother-in-law's garage in Burton (I don't miss them, though the BC 221 was beautifully made and nice to use).

- Digital frequency meter: modern signal generators have these as standard, but I use a stand-alone BK Precision Model 1803 that I picked up on EBay for a few dollars – checked against my crystal calibrator it is 'spot on' right up to 100MHz, even though it is 20 years old. It gives a bit more confidence than using just the signal genny scale;
- VTVM: as these have an extremely high input resistance, they can be attached to the AGC line to act as an S-meter to provide a visual indication of tuning peaks (though note that the AGC voltage in many Eddystones is derived from a diode connected to the primary of the last IF transformer, negating its usefulness for adjustment of the final IF transformer cores). I own several VTVM's – the Heathkit ones, a V-7A dating from the 1950's and an IM11 from the early 1960's, are ok (though their printed circuit construction can result in problems), but my favourite is a traditionally-wired, early-1950's EICO Model 221;
- A dummy aerial: not essential but can make a difference in aligning the RF input circuits – see figure of a typical circuit for broadcast bands. For the SW bands I use a resistor of the specified input impedance connected across the aerial connections, applying the signal genny signal through a 220pf or smaller capacitor;
- Another receiver of known accuracy: a modern digital-readout receiver (eg. Radio Shack DX-394) and/or scanner can be very useful in checking local oscillator operation and frequency – though not for the 'purist' I guess...

And for more accurate/specialist alignment operations:

- Oscilloscope: on its own, an oscilloscope can be used as a visual form of VTVM for alignment work, however it really comes into its own when used with an IF sweep-generator or 'wobbulator' for both AM and FM receiver IF alignment operations. Scopes



- suitable for normal servicing work can be bought new for \$600 or so, or for less than \$150 on EBay (I bought a 1990's dual trace Hitachi 20MHz unit for about \$100 that does all I need), having left my trusty 'Telequipment' 1960's scope back in the UK years ago;
- Wobbulator: by providing a swept range of frequencies (say 50kHz) centred on the desired IF frequency, and the sweep frequency used to trigger the 'scope, the IF response curve can be viewed. This allows for more accurate and symmetrical alignment of multiple-stage IF's and filters in all sets, and also discriminators in FM receivers. Wobbulators can be bought, but simple ones can be constructed from a handful of components (see Lighthouse articles and References);

- Calibrated attenuator: whereas the non-calibrated attenuator in my Triplett signal genny is useful for 'backing-off' signals as the receiver alignment improves during the calibration process, an accurately calibrated attenuator can be used to make quantitative measurements of performance improvements;
- Noise generator: as noted above, tuned circuit peaking can be done after a fashion using a noise source, including background 'atmospheric' noise, however, a specially-designed noise source and accurate attenuator can be used along with other instruments mentioned here to determine actual receiver sensitivity. I used to use one of these when I was 'into' constructing and operating microwave kit many years ago, but no longer have one (see RadCom Volume 82, No.11);
- Grid-dip oscillator (GDO): useful for checking the resonant frequency of tuned circuits (eg. to ascertain the IF in a set where no service information can be obtained) – eg. the 'Edometer' (nice but pricey) or a Heathkit or Millen type (I have a Millen Model 90651-A of late-1960's vintage, picked up on a local fleamarket – like new, in its case and with all coils all for just \$15).



Anything more than the above list is really overkill for the Eddystone range of valve receivers unless accurate, quantitative measures of performance are desired.

Due to the nature of the circuits being adjusted during re-alignment, metal tools (eg. a screwdriver) must not be used, as the metal mass forming the tool will affect the tuning such that the circuit 'de-tunes' when the tool is moved away from the circuit (very frustrating!). The 'special' tools needed for re-alignment work depend to some extent on the receiver type, but most post-WWII Eddystones need only three or four:

- Insulated slot tool(s) – wide and narrow slot widths are useful – I tend to use whittled-down plastic knitting needles in different sizes. These are used for most RF and IF tuning 'slugs';
- Metal-tipped tool for rotary trimmer adjustment – commercially available tools comprise a small metal insert in a plastic handle (using an all-plastic tool can result in the tool snapping on stiffer trimmer rotors);



- Hexagonal plastic tool (readily available from suppliers – see References, though could be whittled from a plastic knitting needle): used for example for adjusting the S.940 BFO coil;
- 'Beehive' trimmer adjuster tool (I use a piece of rubber pipe pushed onto a wooden dowel, though commercially available tools can be purchased).

The above list can be supplemented with a 'tuning wand' made from a piece of plastic rod with a small brass rod mounted on one end and an iron (or steel) rod on the other: placing the brass end into a coil reduces its inductance and the iron rod increases its inductance – useful for checking which way to tune when an oscillator is significantly off-tune.

I have included photos of a selection of trimming tools from my collection (now kept in a trusty *101 Dalmatians* tin after my 1937 Coronation tin became too small after adding some longer-stalk knitting needle-based tools I made to access awkward spots in my Eddystones nether-regions).



### Standard Alignment Procedures

Information provided in manufacturers service data are important in re-aligning receivers, giving the correct method, 'spot' frequencies and 'order of attack' to ensure that the work is done efficiently and correctly – they do however usually assume a reasonable level of familiarity with the theory behind attaining good alignment, the application of alignment techniques and owning/using appropriate equipment and tools. Before starting a re-alignment project therefore:

- Check the general receiver operation to identify that re-alignment is necessary and that the fault or 'deafness' is not due to a defective component, weak valve or 'digital paralysis' on the part of the operator...;
- Try to obtain the correct service information for the receiver (in the case of Eddystones, this is often contained in the operator's manual – even in those short fold-out types as for the S.750 – many of which can be downloaded from the EUG website, 'boatanchor' websites etc. There are many older trade publications that cover domestic receivers that also provide this data);
- If service details cannot be obtained, try to ascertain the correct IF frequency, eg by using a GDO or by connecting the signal genny to the input of the IF stage and manually 'sweeping' the signal genny frequency across the range of possible IF frequencies (85kHz through 1.62Mhz for post WWII Eddystone valve sets), though the majority of broadcast band receivers have an IF around 450 kHz through 465kHz. For this check, the LO section of the tuning gang capacitor should be shorted out and it is better to start at the highest possible frequency and sweep downwards to avoid harmonics of the genny fundamental frequency being incorrectly identified as the IF frequency (eg. responses may be obtained at



113.75kHz and 227.5kHz on the genny dial when the true IF is 455kHz, this being the third and second order harmonics of the former two frequencies;

- If not specified, suitable RF and LO alignment frequencies on each band can usually be determined from selecting a kHz or MHz scale marker at around 10% to 15% of the dial coverage from each end of the scale (ie, not at the extremes of the scale – see diagram at the end of this article);
- Make sure you are familiar with the physical layout of the set – if no layout diagram exists in the manual, compare the circuit with the component arrangement so you know which IF transformer and RF coil/trimmer is which. Make an annotated sketch and take some photos to help;
- Familiarize yourself with the manufacturers recommended alignment procedure: including equipment needed, tools needed and how the set controls should be set-up (eg. position of the RF/IF/AG gains, AGC, BFO, whether part of the tuning gang should be shorted, where to inject the test signals, their strength, frequency, modulation etc, 'spot' frequencies at which to tune the set on each band, order or IF transformer alignment etc);
- If no manufacturers alignment procedure can be found, a 'standard' procedure' can be adopted for straightforward Eddystone valve sets (eg. S.940 for single conversion or S.750 for dual conversion sets – both appended to this article for reference).

Other things to bear in mind are that the signal genny should be isolated as much as possible from the receiver – good screening and grounding are essential and that the smallest level of injected signal should be applied necessary to make the adjustments to the circuit (stronger signals can overload stages and trigger the AGC circuits which can adversely impact the alignment procedure). Also, ensure that the signal genny and the receiver have been running for at least 30 minutes prior to starting re-alignment.

For re-alignment purposes, the circuits in a superhet can be reduced to three sections as shown in the figure, right:

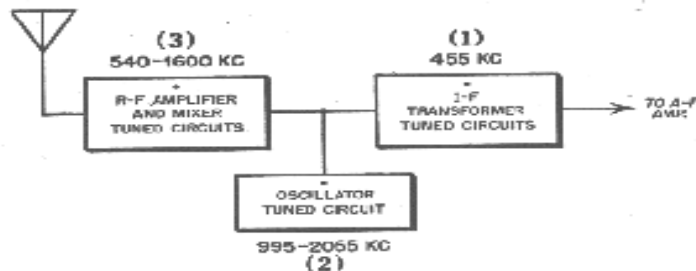

1. the IF tuned circuits (1) are aligned to resonate at the same frequency, the nominal IF frequency, eg, 85kHz, 100kHz, 450kHz or 1.6MHz, or when a crystal filter is present, the actual resonant frequency of the crystal with the phasing control in mid-position;
2. the RF amplifier and mixer circuits (3) are aligned to resonate at the same frequency for any given adjustment of the tuning dial; and
3. the LO (2) is tuned to another frequency separated from the RF amplifier tuned frequency by the value of the IF frequency at any given adjustment of the tuning dial. In the case of a double-superhet, a second LO is used, normally operating at a fixed frequency separated from the first IF frequency by an offset equal to the

second IF frequency (though in some sets this can be varied to provide a form of bandspread, as in the Eddystone S.830 series).

The standard order of re-alignment is the IF stages first, then the LO(s), then the mixer(s) and RF amplifier stage(s). The reasons for this are that the IF frequency is a fixed value for a particular model and is independent of other circuits; correct adjustment of the LO frequency is dependant on an accurate IF frequency being already set; and the mixer and RF stages are dependant on proper alignment of both the IF and LO stages. Next I will briefly describe a typical equipment set up and method for each stage. It is normal to repeat the procedure at least once (some sections may require several iterations to obtain acceptable results) as adjustments of one setting often affects another.

### IF Stages and BFO Alignment Method and Issues



The IF stages determine, to a large extent, the receiver sensitivity and selectivity and are critical to obtaining optimum performance in a superhet. Alignment of the IF stages is fairly straightforward as all the circuits are tuned to the same frequency: either the nominal IF frequency, as specified in the receiver service data/manual, or if a crystal filter is present, the actual resonant frequency of its crystal.

Typically in a communications receiver, the signal genny, set for the desired IF frequency as noted above, is coupled to the mixer stage input tuned circuit (mixer valve grid) with the LO disabled by shorting out the LO section of the tuning gang capacitor. The coupling is made with a 50pf to 0.1uf capacitor, depending on the set – use the lowest value possible that provides adequate indication on the output meter, this will minimize de-tuning of the mixer tuned circuits due to loading by the genny output impedance. However, in broadcast sets (with no RF amplifier stages ahead of the mixer), coupling the genny to the aerial input usually provides sufficient coupling to undertake IF alignment (this also ensures that no de-tuning of the first IF and mixer stages occurs due to the loading effect of the genny mentioned earlier). The output meter is normally connected in parallel with the loudspeaker.

When the genny and output meter are connected and an indication is present on the output meter, the IF transformer adjustments can be made – the normal procedure is to

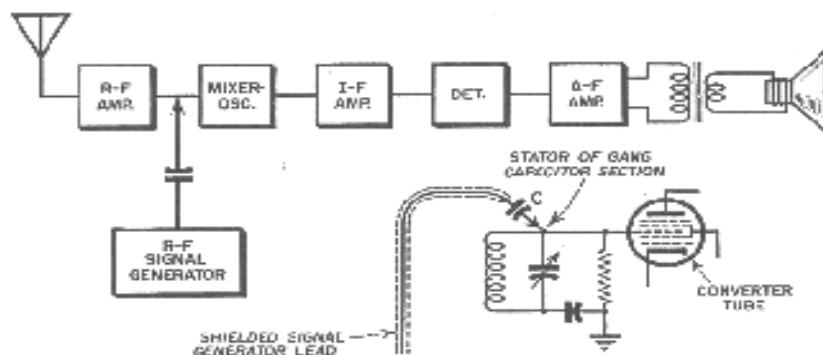

adjust the last transformer first (using the coil cores or trimmer capacitor as present in the receiver) and once these core/trimmers have been adjusted to peak on the output meter, proceed to the next IF transformer (closer to the mixer stage) and so on, reducing the signal genny output as the IF stage sensitivity increases with closer alignment. The process should be repeated at least once as there is some interaction between the circuits, always using the lowest genny signal level that provides a useful indication on the output meter to avoid influence of the AGC circuit or non-linearity due to overloading (note: temporarily disconnecting or disabling the AGC circuit may be needed in sets where this cannot be switched off – the simplest way is to short the AGC bus to ground).

The shape of the IF response curve can be adjusted by careful tuning of the IF stages and sometimes a 'staggered tuning' method of alignment is specified for broadcast sets, giving a wider passband and steeper 'skirts' – see the 'Shorts' article on receiver selectivity for more information on this. An oscilloscope/wobbulator/signal genny combo may be used to provide a visual representation of the IF response curve, with 'real-time' observation of the effect of the tweaking possible in order to provide the desired response (within the constraints of the receiver circuitry). The wobbulator normally provides visual 'markers' to identify the centre frequency and fixed offsets from it to allow accurate adjustment and symmetry.

Once the IF stages are aligned, switch off the signal genny's modulation and switch on the receiver BFO. Centre the BFO control so that the variable capacitor (or resistor if a varicap diode is used) is set at half of its travel and then adjust the BFO coil core or trimmer to give zero beat with the genny signal.



### LO Stages Alignment Method and Issues

The LO determines the accuracy of the dial readings of the receiver as well as its frequency stability, and has no effect on the sensitivity or selectivity of the receiver: once the IF frequency is set, only the LO can affect the dial setting and accuracy. The adjustments to the LO tuned circuits are therefore simply to match the received frequency to the dial markings. Prior to starting any adjustments of the LO, the operation of the dial mechanism should be checked for any signs of slippage or other malfunction – there is little point in aligning the LO only for the dial cord to start slipping... also, check that the full travel of the dial corresponds to the full swing of the tuning gang capacitor, or is set as recommended by the manufacturer.

Range	Trimming Frequency	Trimmer	Padding Frequency	Core
1	27.0 Mc/s	C49	13.5 Mc/s	L16
2	11.5 Mc/s	C50	5.8 Mc/s	L17
3	4.8 Mc/s	C51	2.5 Mc/s	L18
4	2.2 Mc/s	C52	1.1 Mc/s	L19
5	950 kc/s	C53	500 kc/s	L20

The ability of the Lo to maintain accurate dial readings across its tuning range is termed 'tracking'. Normally, the LO tuned circuit inductance is adjusted for the lower frequencies in a given tuning range (ie, permeability adjustment by moving an iron dust or ferrite core) and by a trimmer capacitor in parallel with the tuning gang LO capacitor for the higher frequencies. A 'padder' capacitor may, in some cases, be placed in series with the LO tuning capacitor to allow adjustment at the lower end of the range instead of the permeability arrangement. Inserting the cores further into the transformer coils lowers the resonant frequency (inductance value increases) as does increasing the trimmer capacity, however, the inductance changes affect the lower end of the frequency range more and the trimmers have most influence at the higher end of the range.

It can be difficult to achieve perfect tracking across the tuning range, however, an acceptable compromise is normally achieved by the following method. Standard 'spot' tracking frequencies are specified (or selected) towards either end of the dial tuning span (see comments above on this) – the Eddystone manuals usually provide a table showing these for each Band, eg. the one for the S.940 is shown above.

With the signal genny set to 'internal modulation' (about 30%) and coupled to the receiver aerial connections by a dummy aerial (or small capacitor and resistor), the general procedure to be followed for each Band is:

- Carry out a quick check to see if the receiver is approximately on-frequency using the crystal calibrator at appropriate marker intervals, injecting the crystal calibrator signal into the aerial socket of the receiver. Some sets have an internal 100kHz crystal calibrator that can be used, however, if the receiver is badly out of alignment, which marker is which may not be clear (particularly on the HF bands): a 1MHz or even a 5MHz marker is more useful for this check;
- Adjust the receiver dial to the specified high tracking frequency;
- Adjust the signal genny to the same frequency (on the signal genny dial) and check whether a signal is received or not – if it is, then no adjustment of that Band's LO trimmer is needed. If it is not, tune the receiver to see if the genny signal can be received above or below the indicated frequency. If the signal is found above or below the indicated frequency, adjust the trimmer capacitor until the dial reading corresponds to the signal genny frequency;
- Adjust the receiver dial to the specified low tracking frequency;
- Adjust the signal genny to the same frequency (on the signal genny dial) and check whether a signal is received or not – if it is, then no adjustment of that Band's LO coil core ('slug') is needed. If it is not, tune the receiver to see if the genny signal can be received above or below the indicated frequency. If the signal is found above or below the indicated frequency, adjust the coil core (or



padder capacitor if one is used in the receiver circuit) until the dial reading corresponds to the signal genny frequency;

- Return the receiver dial to the specified high tracking frequency and repeat the entire procedure as many times as it takes to attain reasonable tracking across the Band (two to four times is typical).

If the accuracy of the signal genny is not known or a digital readout is not available, check spot frequencies with a crystal calibrator across the Band. If the tracking cannot be adjusted to attain reasonably good correlation between the applied signal and dial readings, suspect that the LO is oscillating on the wrong side of the IF. This can easily be checked if you have access to another receiver of known accuracy (preferably with a digital readout) by listening for the LO signal on that set. Eddystones (and most other broadcast and shortwave radios) normally run their LO at a frequency higher than the received frequency offset by the IF frequency, thus if the receiver dial indicates 14.7MHz and the set's IF is 450kHz, the LO should be running at 15.15MHz (not 14.25MHz, which would provide the same IF, but would likely give very poor tracking). It is useful to remember that *'if the oscillator frequency is higher than the received signal the lower-frequency position on the signal genny dial or the higher frequency position of the receiver dial is identified as the proper signal at which to align'* (Radio and Television Receiver Troubleshooting and Repair, Ghirardi & Johnson).

### RF and Mixer Stages

Adjustment of these circuits affects the sensitivity and selectivity of the receiver – it is assumed that the IF and LO circuits have already been aligned and the signal genny is still set up with 30% modulation, is coupled to the aerial circuit as noted above, the output meter is still connected across the speaker and the receiver controls are set as per the manufacturers instructions – normally all gains fully on, AGC off and BFO off. Standard 'spot' frequencies are specified (or selected) towards either end of the dial tuning span, often the same as for the LO adjustments noted above – the Eddystone manuals usually provide a table showing these for each Band, eg. those for the S.940 are shown, right.

Range	Trimming Adjustments			
	Frequency	1st RF	2nd RF	Mixer
1	27.0 Mc/s	C1	C18	C33
2	11.5 Mc/s	C2	C19	C34
3	4.8 Mc/s	C3	C20	C35
4	2.2 Mc/s	C4	C21	C36
5	950 kc/s	C5	C22	C37

Range	Padding Adjustments (Core)			
	Frequency	1st RF	2nd RF	Mixer
1	13.5 Mc/s	L1	L6	L11
2	5.8 Mc/s	L2	L7	L12
3	2.5 Mc/s	L3	L8	L13
4	1.1 Mc/s	L4	L9	L14
5	500 kc/s	L5	L10	L15

The general procedure to be followed for each Band is:

- Adjust the receiver dial to the specified high 'spot' frequency;
- Adjust the signal genny and the receiver to the same frequency;
- Adjust each of the aerial, RF stage(s) and mixer stage trimmer capacitors for the Band being aligned until maximum indication (peak) is indicated on the output meter, reducing the signal genny output to the minimum needed to obtain a reasonable deflection on the meter – adjustment of the trimmers in the various stages (Aerial, RF, Mixer) for each Band can be done in no particular order unless one is specified by the manufacturer;
- Adjust the receiver dial and signal genny to the specified low 'spot' frequency;
- Adjust the coil core (or padder capacitor) for the Band being aligned until maximum indication (peak) is indicated on the output meter, reducing the signal genny output to the minimum needed to obtain a reasonable deflection on the meter – adjustment of the cores in the various stages (Aerial, RF, Mixer) for each Band can be done in no particular order unless one is specified by the manufacturer, though I normally start with the mixer, then RF and finally the Aerial;
- Return the receiver dial to the specified high 'spot' frequency and repeat the entire procedure as many times as it takes to attain reasonable consistency of output when the receiver is tuned across the Band (twice is usually sufficient).

Some receiver servicing texts describe a 'dial rocking' procedure for attaining optimum compromise between dial accuracy and receiver sensitivity, but to be honest, I have never had cause to try this (eg, see References: Elements of Radio Servicing, pp446 and Radio & Television Receiver Troubleshooting and Repair, pp426). Others suggest bending the outer, slotted, rotor plates on the tuning capacitor gang to aid tracking (photo right), again, I have never had to do this (seems a bit 'rough and ready').



### Potential Problems...

Some common pitfalls to achieving a successful re-alignment project are:

- The set has an undetected fault(s) that prevent it functioning correctly, even if aligned;
- The test equipment you are using is not up to the job, eg. poorly calibrated or drifts;
- You think your ears are a linear output meter (they are not, they are more semi-logarithmic);
- The AGC is left on;
- The LO is not disabled during IF alignment;
- The LO is tuned to the wrong side of the received signal;



- You are trying to tune the IF to a signal genny harmonic;
- The signal genny output is too closely coupled to the circuit under test and/or its output is too high;
- You get distracted and momentarily forget which Band you are switched to and hopelessly keep turning the wrong trimmer or core... (I know, I have done it!), with the resulting frustration of having to start from scratch on that Band.... It helps to take a photo showing the positions of the various trimmers and coils before starting so at least you can approximate where to start from again in this eventuality (of course it could not happen to you); and finally,
- Don't lock the cores/trimmers in place using bikini wax, chewing gum or super-glue – some poor sap (maybe even you) will want to re-trim them some day, so make it easy for them and use a small piece of fine elastic thread for the cores (maybe with a minute dab of silicon grease) and the smallest dab of nail polish for the trimmers (or don't bother doing anything – unless the set is subject to vibration, eg from an internal speaker, they are unlikely to move too far);

### Checking Your Work

Once satisfied with the re-alignment, go through each Band again in order, checking and comparing receiver sensitivity throughout its range: it should not vary by much, though some slight drop-off in performance may be present at the upper end of its highest frequency range – if there are significant differences, then re-check the alignment on the affected band(s). The type of instruments noted here are not really suitable for quantitative measurements of receiver performance beyond the basic sensitivity checking as described, however, some comparative checks can be made if a receiver of known spec is available, with the output from a well-attenuated signal genny being switched between the two receivers (though make sure that the receivers both 'see' their design aerial impedance). Some 'on-the-air' checks and/or comparisons are also in order: check that the performance meets expectations on both weak and strong signals.

If you are using a signal genny with an accurate, calibrated attenuator (so that its output level can be quantified), overall receiver sensitivity can be measured on each Band using the output meter as described in the manufactures alignment instructions (see typical Eddystone instructions attached). This is usually specified as the signal level (eg. 7uV) needed at the aerial input to give the 'standard' audio output level of 50mW (note: this is equivalent to 0.387vAC measured across a 3ohm speaker or dummy load).

### Some of my Eddystone Experiences

My restoration articles dealing with my S.750 and S.940 describe some specific experiences of re-aligning Eddystone sets. Apart from an issue with Band 2 in my S.750, which had the LO tracking low of the received signal, alignment has been straightforward, following the procedure as described in the manuals.

Gerry O'Hara, G8GUH, Vancouver, BC, Canada, November, 2006

### Some Useful References

- Radio Communications Handbook, RSGB (eg. 4<sup>th</sup> Ed, Chapter 4
- Radio Amateurs Handbook, ARRL (eg. 31<sup>st</sup> Ed. Chapter 5)
- Elements of Radio Servicing, W Markus and A Levy, 1955 (2<sup>nd</sup> Ed. Chapter 25)
- Radio Engineering, F. Terman, 1947, (3<sup>rd</sup> Ed. Chapter 15)
- Radio Servicing: Theory and Practice, A. Markus, 1948 (Chapter 15)
- Radio and Television Receiver Troubleshooting and Repair, Ghirardi & Johnson, 1952, (Chapter 12)
- Radio and Television Receiver Circuitry and Operation, Ghirardi & Johnson, 1951 (Chapter 4)
- RSGB RadCom, Vol.82, No.11, November, 2006, pp38 – 39
- Various sections of Eddystone manuals downloaded from the EUG web site and specific articles in Lighthouse including:

Subject	Issue	Page
alignment frequencies .....	4 .....	3
(730) i.f alignment.....	60 .....	18
(830/4) alignment query .....	64 .....	17
(840A) r.f. & oscillator realignment.....	2 .....	2
(870A) realignment, aerial tuning stage .....	12 .....	13
(940) alignment, sweep generator .....	72 .....	35
(EA12) realignment .....	26 .....	19
(EB35 MkII) realignment & overhaul .....	29 .....	19
(EB36) realignment .....	33 .....	7
(EB37) realignment considered.....	29 .....	21

- Some web-based articles/resources on subjects covered in this article include:
  - [http://www.oselectronics.com/ose\\_p62.htm](http://www.oselectronics.com/ose_p62.htm) (trim tool supply)
  - <http://www.antiqueradios.org/gazette/align.htm>
  - [http://www.vintage-radio.com/repair-restore-information/transistor\\_alignment.html](http://www.vintage-radio.com/repair-restore-information/transistor_alignment.html)  
(ok, it mentions three-legged fuses, but it is on alignment...)
  - [http://www.archive.org/details/Elements\\_Of\\_Radio\\_Servicing/](http://www.archive.org/details/Elements_Of_Radio_Servicing/)
  - <http://www.vk2bv.org/radio>

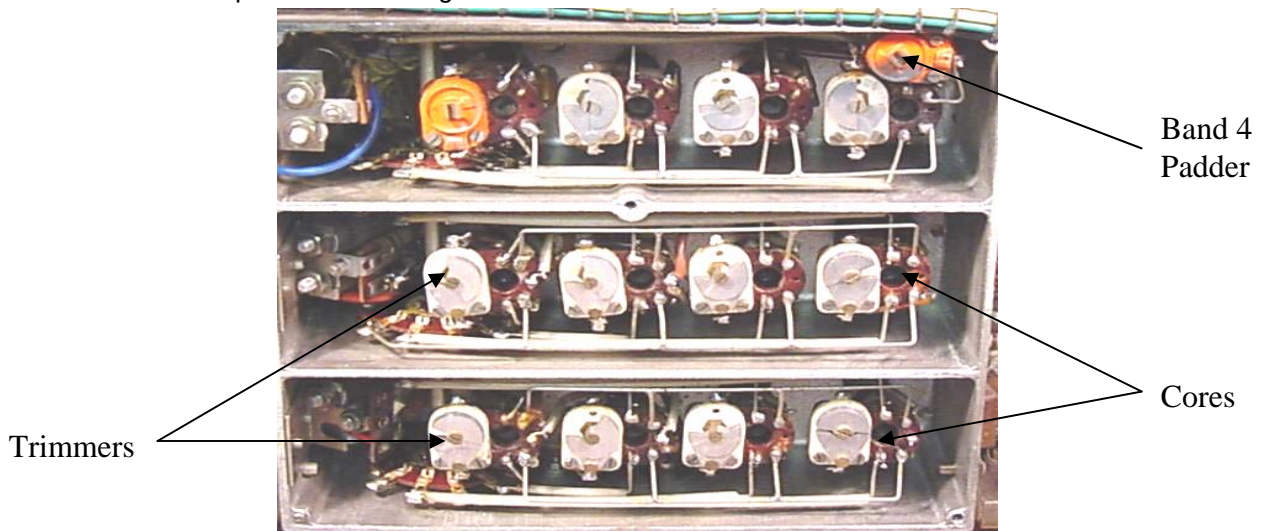

An S.750 coilbox – scary? – not if you read this article...



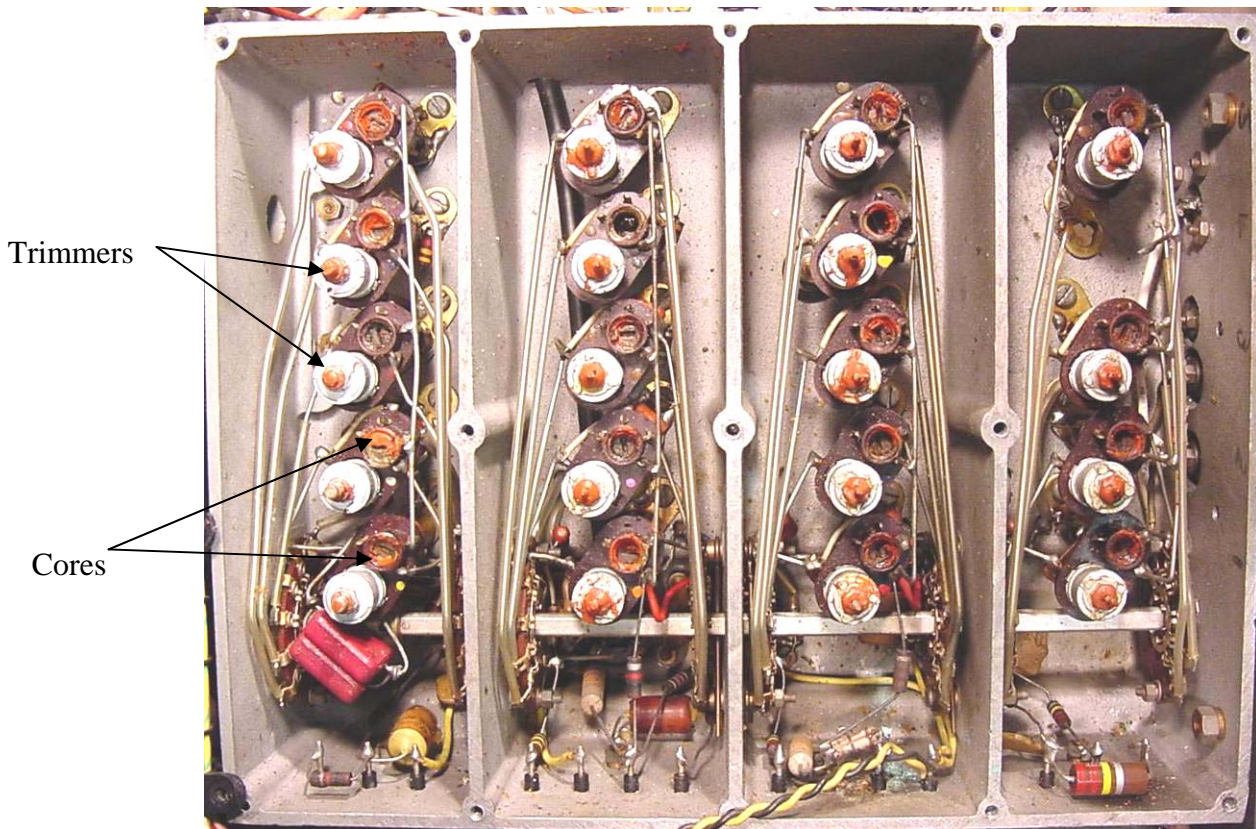

LO Stage

Mixer Stage

RF Stages

Aerial input  
(L4/C4  
missing)

An S.940 coilbox – a nightmare? – not if you read this article...

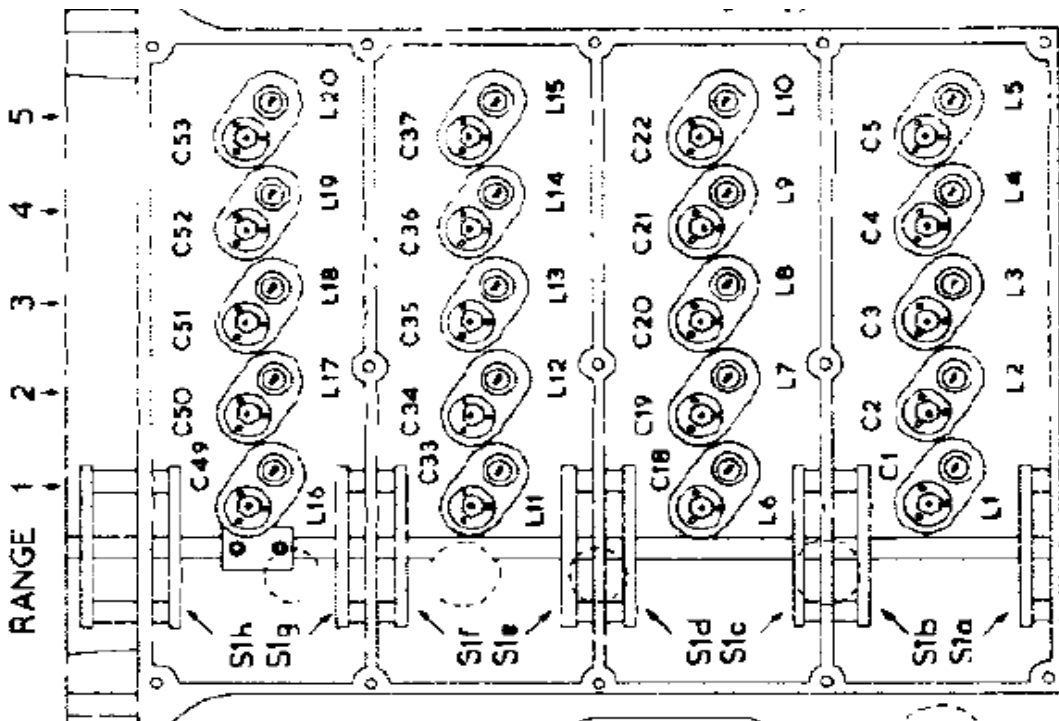

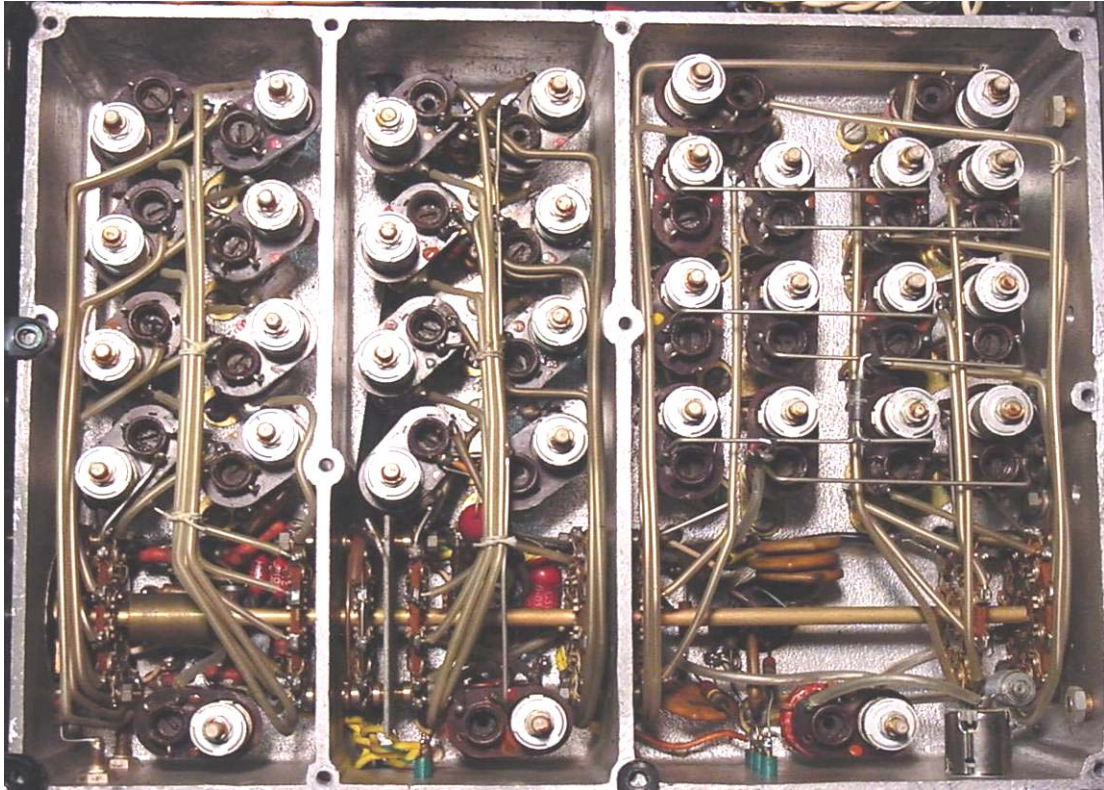

and neither should one be from an S.830, well maybe just a bit...

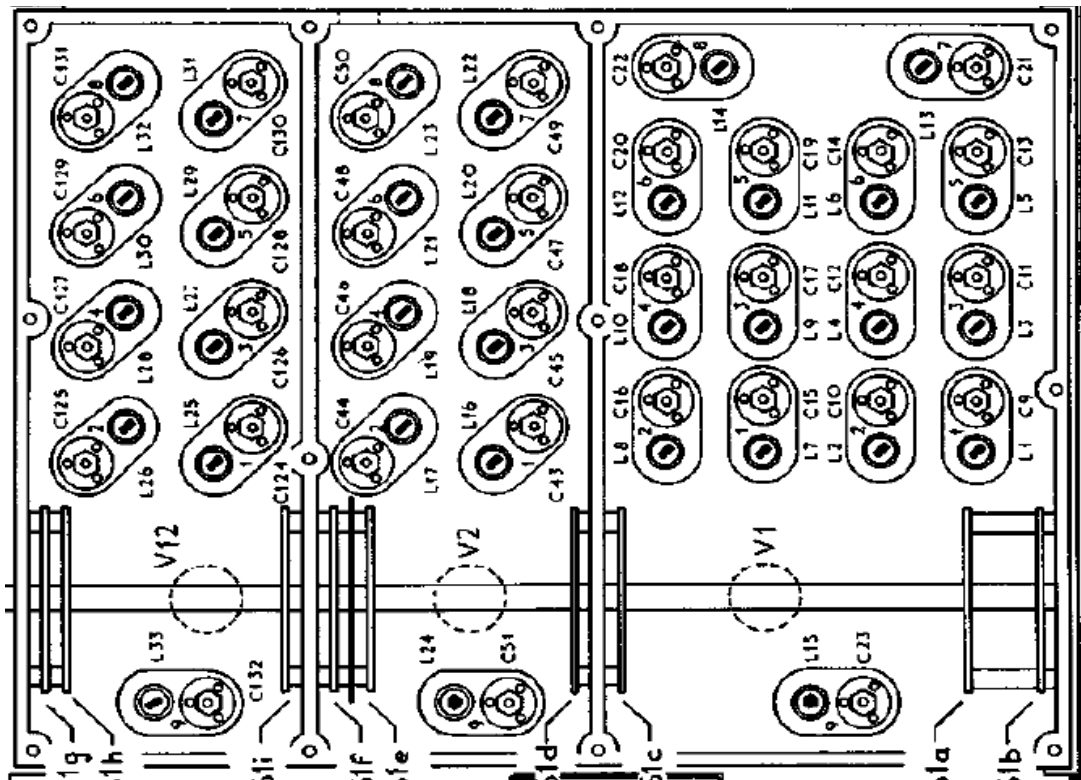

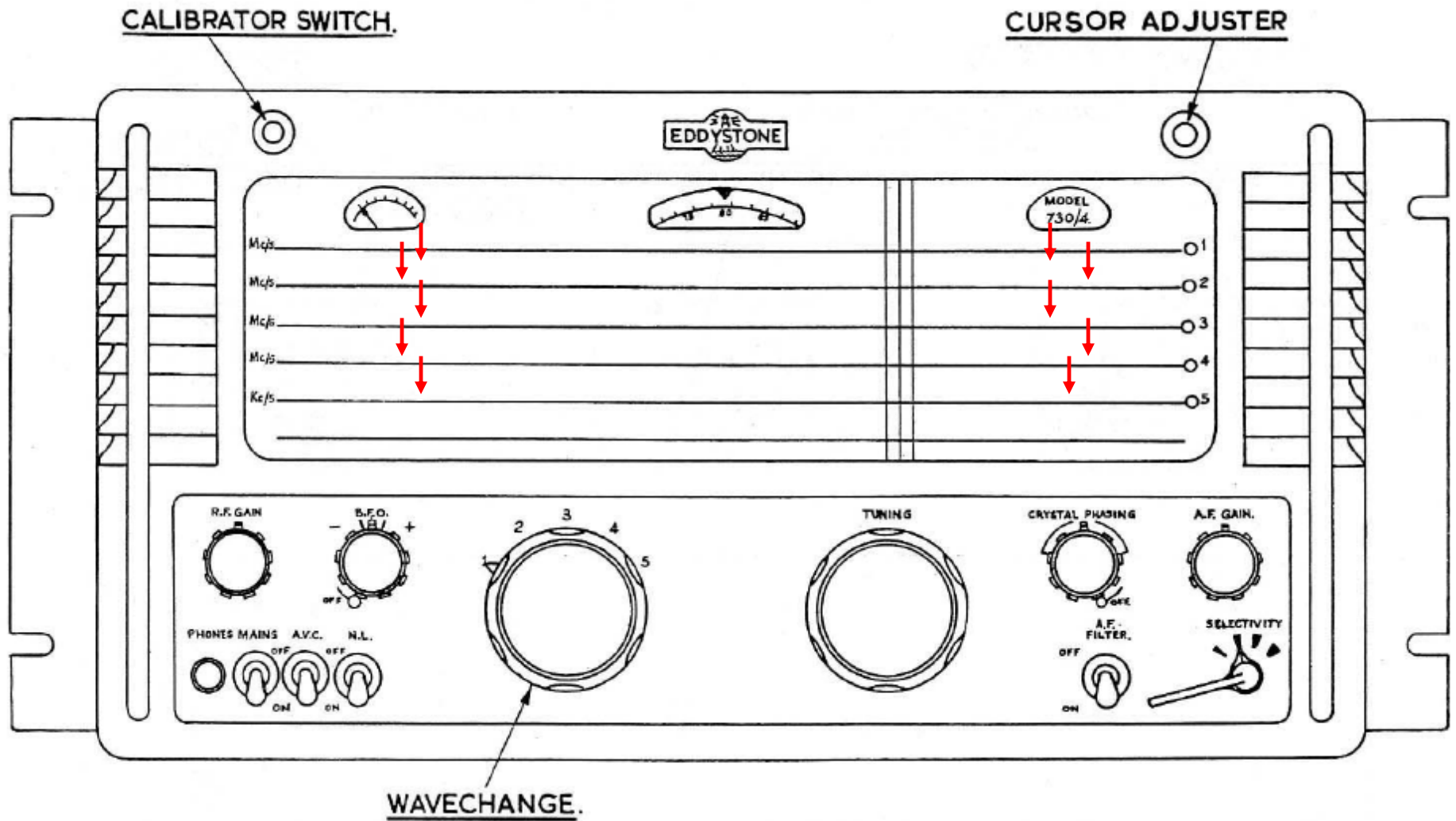

Typical locations for 'spot' tracking frequencies shown with a ↓

# EDDYSTONE '750'

## ALIGNMENT INSTRUCTIONS

It is assumed that test instruments are available --- in particular, a Signal Generator covering 85 Kc/s. to 32 Mc/s. and provided with internal modulation (30%) and a calibrated attenuator; and an audio output meter, calibrated in milliwatts and decibels and adjustable to match an impedance of 25 ohms. Trimming should be carried out with a non-metallic tool such as the Eddystone Cat. No. 122T.

### IF STAGES.

The controls should be set as follows :

- |                      |                        |
|----------------------|------------------------|
| RF Gain minimum      | Band Selector Range 1. |
| IF Gain maximum      | BFO Off.               |
| AF Gain maximum      | Noise Limiter Off      |
| Selectivity maximum. |                        |

A 30% modulated input, at 85 Kc/s., is applied between chassis and the grid of V4\* (the second frequency changer), and the four cores in the IF transformers marked "2nd" and "3rd" in Fig. 1 adjusted to give maximum output, as indicated on the output meter. The attenuator of the S.G. should be adjusted as necessary to prevent the needle of the output meter going off the scale. An input of about 280 microvolts will normally be required to give 50 milliwatts at the speaker terminals.

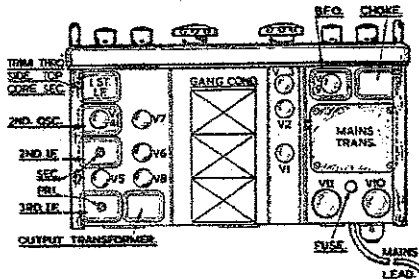

Fig. 1

Leaving the controls and connections undisturbed, the input frequency should be changed to 1620 Kc/s. and the second oscillator adjusted, by moving the core in the V4 screening can (see Fig. 3), until output is maximum. Because of the slight loss in conversion, a greater input (by some 2 or 3 db) will be required to give 50 milliwatts output. The change to 85 Kc/s. can be obtained with the oscillator on either the high or the low side of 1620 Kc/s. and two positions of oscillator core will give output --- the lower frequency position, with the core furthest in, is the correct one.

The band selector switch should now be moved to "G" and the 1620 Kc/s. input applied between chassis and the stator of the centre section of the gang condenser. The primary and secondary cores in the first IF transformer (see Fig. 1) are then adjusted to give maximum output and a further very slight and very careful adjustment of the V4 oscillator core may give an improvement. The final IF sensitivity should be such that 50 milliwatts output is produced for an input (at 1620 Kc/s.) of between 5 and 10 microvolts.

### BFO ADJUSTMENT.

With the BFO switch at "off," a modulated signal should be applied and tuned in accurately on the receiver. The modulation is switched off, the BFO switched on and, with the pitch control at half-mesh (white spot at top), the core in the BFO unit (see Fig. 3) is set to give zero beat.

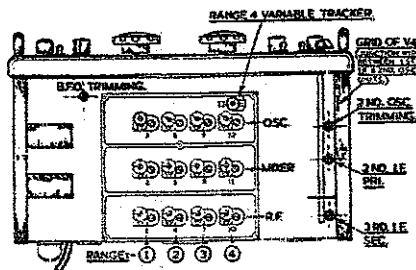

Fig. 3

### RF ALIGNMENT.

The controls remain as before but with the RF gain also turned to maximum. Should it be found necessary to correct discrepancies in the scale calibration, the output from a Crystal Frequency Standard should be applied to the aerial terminals (the calibration of most Signal Generators is not accurate enough). Adjustment is then made to the cores and trimmers appropriate to each range, in the oscillator section of the coil box (see Fig. 3). Checks and adjustments should be made at the frequencies given below, using the TRIMMER CONDENSER at the higher frequency end of the scale and the CORE at the lower frequency end. The BFO should be switched on for these tests, with the pitch control at "12 o'clock." The

ceramic tracker condenser shown in Fig. 3 has been very carefully adjusted for proper tracking on Range 4 and it is not advisable to touch it.

- |          |               |            |
|----------|---------------|------------|
| Range 1. | 13 Mc/s. and  | 31 Mc/s.   |
| Range 2. | 5 Mc/s. and   | 11 Mc/s.   |
| Range 3. | 2 Mc/s. and   | 4 Mc/s.    |
| Range 4. | 500 Kc/s. and | 1400 Kc/s. |

To proceed with the alignment of the RF and Mixer stages, the BFO is switched off, the crystal oscillator removed and the modulated output from the Signal Generator connected to the aerial and earth terminals, via the dummy aerial. The attenuator is set to give an output of between 10 and 20 microvolts.

A signal on 13 Mc/s. should be injected and tuned in on Range 1 of the receiver. The CORES in the RF and Mixer stages are then adjusted for maximum output as indicated by the output meter. Next, the S.G. is set to 30 Mc/s. and the output peaked by adjustment of the TRIMMER CONDENSERS. Adjustment is again made at 13 Mc/s. and the procedure repeated until no further improvement is possible.

The other ranges are aligned in the same way, using the following high and low frequency alignment points on each range :

Range	Trimmer Frequency	Core Frequency	RF Coil	Mixer Coil
1	30 Mc/s.	13 Mc/s.	1	2
2	11 Mc/s.	4.7 Mc/s.	4	5
3	4.2 Mc/s.	2 Mc/s.	7	8
4	1350 Kc/s.	550 Kc/s.	10	11

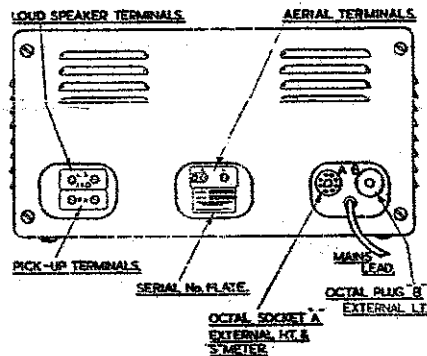

Fig. 2

### VOLTAGE VALUES.

The voltages are between the point indicated and the chassis. Set the receiver at 28 Mc/s. on Range 1 with the aerial shorted out, IF and RF controls set at maximum. AF gain control set at minimum with BFO on. Two sets of values are given using different meters as shown. It will be evident that the actual voltage indicated depends on the meter employed. A tolerance of plus or minus 5% should be allowed on the values given.

Circuit Reference	Weston 1,000 ohms/Volt	Avo Model 40
A	225 volts	225 volts
B	98	90
C	1.0	.95
D	82	80
E	235	236
F	1.6	1.5
G	98	73
H	78	75
J	232	230
K	1.4	1.2
L	85	80
M	235	235
N	85	80
P	0.9	0.9
Q	65	13
R	1.0	0.7
S	235	235
T	227	225
U	4.2	4.1
V	150	150
W	235	235
X	275	272
Y	75	70
Z	2.0	0.9
A—	250	A.C. 250
B—	250	A.C. 250

\* As specified under the chassis (see Fig. 3)

**Cleaning Scale and Scale Window**

1. Locate the three screws disposed vertically at each end of the rear of the scale plate. Take out the centre screw at each end and remove the small side castings at the extremities of the glass window.
2. Remove the three dial lamp holders from the rear of the scale support. These are clipped into position and are easily disengaged from the fixing slots by squeezing together the two sides of the holder.
3. Remove the four countersunk screws along the top edge of the panel and take out the long scale support.
4. The glass is now free and can be removed by lifting up and tilting back slightly.

**Valve and Dial Lamp Replacement**

The valves used in the Model 940 are standard types and no difficulty should be experienced in obtaining replacements. Any recognised equivalent is suitable if the type specified is not available, e.g. ECH81 can be used in lieu of 6AJ8, EB91 for 6AL5, etc.

All valves are easy of access and can be changed without difficulty. Screens or retaining clips must be replaced after fitting a new valve.

Dial lamps are rated at 6.5V @ 0.3A and are standard miniature bayonet types.

**Re-alignment — General**

In the unlikely event of a complete re-alignment being necessary, the following instructions should be followed in full. In the more usual case of partial alignment required to compensate for ageing components, etc. the relevant instructions can be extracted as required.

It must be stressed that alignment adjustments should not be tampered with unless there is a clear indication that alignment is in fact required. Alignment should only be carried out by fully skilled technicians equipped with suitable test instruments.

**Re-alignment of the IF Transformers and BFO**

*Test Equipment Required.*

*Signal Generator covering the intermediate frequency of 450 kc/s with modulation at 400 c/s.*

*Output Meter matched to 2.5/3Ω.*

*Trimming tool (screwdriver type).*

First disable the Local Oscillator by shorting out the section of the tuning gang nearest to the front panel. Set the Wave-change switch to '5,' Tuning to 700 kc/s and the RF and

AF Gains at maximum. Switch off the Noise Limiter and AGC and put the Mode switch in the 'AM' position. Alignment must be carried out with the crystal filter in circuit so the Selectivity switch should be at 'CRYSTAL.' Adjust the Phasing control so that the capacitor is at its 'half-capacity' setting and check that this occurs when the index mark on the control knob is at 12 o'clock.

Connect the Signal Generator output lead to the stator of the Mixer section of the tuning gang (adjacent to Oscillator section) and the Output Meter and Loudspeaker to the 2.5Ω terminals at the rear. Allow 10—15 minutes for the equipment to reach operating temperature and then tune the Signal Generator to approximately 450 kc/s with modulation at a depth of 30% (400 c/s).

Now set the attenuator to a suitable level and tune the Generator for a peak reading on the Output Meter. It should be remembered that the receiver IF is in its most selective position and the tuning adjustment must be made very carefully to ensure that the output frequency is set accurately to the crystal peak. The attenuator should be adjusted to give a convenient reading on the Output Meter.

Peak the ferrite cores in T1—T4 (see Plan view for location) to obtain maximum reading on the Output Meter. It should be noted that the cores will tune in two positions; i.e. to an 'inner' and an 'outer' peak. All cores except the bottom (primary) core of T1 are set to the 'outer' peak; i.e. the one which occurs when the core is furthest from the opposite coil. The bottom core of T1 is set to the 'inner' peak while the core in the crystal filter output coil (T2) can be set to either peak.

Increase the attenuation as alignment proceeds and ensure that on completion a sensitivity of the order 7μV is obtained for an output of 50mW (IF selectivity at 'MAX'). If this figure is not achieved, stage checks should be carried out with the Generator applied directly to pin 1 (grid) of V5 and V6. Typical sensitivities to be expected are (1) at grid of V5: 220μV for 50mW output, and (2) at grid of V6: 14mV for 50mW output. A low sensitivity in either position will most likely be due to a faulty valve (6BA6) or low gain in the audio stages. AF sensitivity is of the order 120mV for 50mW output (1,000 c/s) with the signal applied at the AF Input terminals. (All sensitivities quoted with loudspeaker disconnected).

After the amplifier has been aligned in the 'CRYSTAL' position, a check should be made on the symmetry of the response in the 'MAX' and 'MIN' positions. If the response is asymmetrical in the 'MIN' position, slight re-adjustment of the bottom (primary) core of T1 will allow correction without affecting the response in the other positions of the switch.

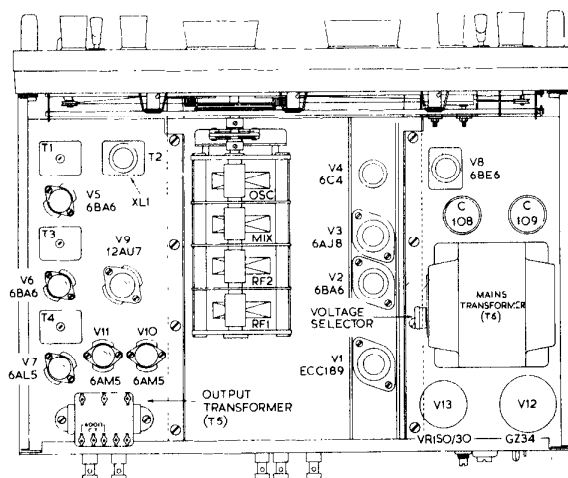

Plan view of Receiver

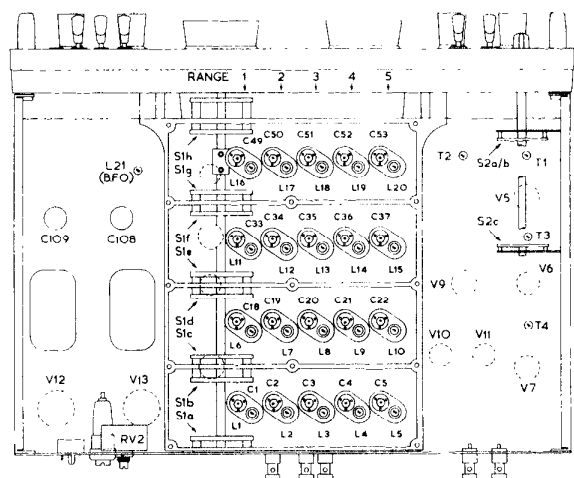

Underside view of Receiver

Once the alignment of the IF Transformers has been completed, check that the Generator is tuned to the crystal frequency and then cut the modulation. Set the receiver Mode switch to the 'CW/SSB' position and adjust the BFO Pitch control so that the capacitor is at 'half-capacity.' Check that, at this setting, the control knob index lies at 12 o'clock.

Now adjust the BFO core (L21) for zero beat and then check that the swing of the control covers at least 3 kc/s above and below the centre frequency.

This completes alignment of the receiver IF Section: the Generator and the shorting link on the forward section of the tuning gang can now be removed.

Range	Trimming Adjustments			
	Frequency	1st RF	2nd RF	Mixer
1	27.0 Mc/s	C1	C18	C33
2	11.5 Mc/s	C2	C19	C34
3	4.8 Mc/s	C3	C20	C35
4	2.2 Mc/s	C4	C21	C36
5	950 kc/s	C5	C22	C37

### RF Alignment

#### Test Equipment Required.

Crystal Calibrator giving markers at 1 Mc/s and 100 kc/s intervals over the range 480 kc/s — 30 Mc/s.

Standard Signal Generator covering the range 480 kc/s — 30 Mc/s with an output impedance of  $75\Omega$  and modulation at 400 c/s.

Output Meter matched to  $2.5/3\Omega$ .

Trimming tools (screwdriver and concentric trimmer types).

The first step in re-alignment of the RF Section is a check on the accuracy of the dial calibration to ascertain whether adjustments are required in the Local Oscillator Stage. Set up the receiver for CW reception with the BFO in the centre of the IF passband. Connect the Crystal Calibrator to the aerial input terminals and check the scale accuracy at 100 kc/s intervals throughout each of the five ranges. Calibration accuracy should be within 0.5% (i.e. within 25 kc/s at 5 Mc/s, 75 kc/s at 15 Mc/s etc.). If the indications are that the calibration accuracy is outside the limits quoted, re-alignment should be carried out using normal tracking procedure. Adjustments should be made at the spot frequencies listed in the Table below. When the Signal Generator is used as the signal source for oscillator alignment it must be standardised against the Crystal Calibrator.

Range	Padding Adjustments (Core)			
	Frequency	1st RF	2nd RF	Mixer
1	13.5 Mc/s	L1	L6	L11
2	5.8 Mc/s	L2	L7	L12
3	2.5 Mc/s	L3	L8	L13
4	1.1 Mc/s	L4	L9	L14
5	500 kc/s	L5	L10	L15

## SPARES

Spare parts should be ordered by quoting the circuit reference (where applicable) and the part number given in the list below.

Range	Trimming Frequency	Trimmer	Padding Frequency	Core
1	27.0 Mc/s	C49	13.5 Mc/s	L16
2	11.5 Mc/s	C50	5.8 Mc/s	L17
3	4.8 Mc/s	C51	2.5 Mc/s	L18
4	2.2 Mc/s	C52	1.1 Mc/s	L19
5	950 kc/s	C53	500 kc/s	L20

The oscillator tracks 'high' on all ranges. On Ranges 1 and 2 there is a possibility of setting the oscillator on the low side of the signal and a check should be made to ensure that the response with minimum capacity or minimum inductance is selected. Care should be taken to balance any interaction between the trimming and padding adjustments which should be repeated at least twice to achieve the desired accuracy.

Once the scale calibration has been checked and corrected if necessary, alignment of the RF and Mixer circuits can be commenced. The Output Meter should be connected to provide a clearer indication of maximum output than is possible with the speaker alone. The receiver input impedance is  $75\Omega$  and the Signal Generator should be arranged to match this impedance when connected to the 'A1' and 'E' terminals at the rear. Modulation should be 30% at 400 c/s. Alignment adjustments are made at the following frequencies, tuning for maximum output with the appropriate trimmer or core. As with oscillator alignment each adjustment should be repeated at least twice to reduce errors due to interaction.

### Coils

L1 : D2677/1	L11 : D2677/2
L2 : D2680	L12 : D2681/1
L3 : D2683	L13 : D2684/1
L4 : D2686/1	L14 : D2687
L5 : D2689/1	L15 : D2690/1
L6 : D2678/1	L16 : D3281
L7 : D2680/1	L17 : D3282
L8 : D2684	L18 : D3283
L9 : D2687	L19 : D3284
L10 : D2690/1	L20 : D3285

### Transformers and Choke

T1 : D2901	T5 : 6146P
T2 : D2892*	T6 : 3937P
T3 : D2924	CH1 : 5863/1P
T4 : D2902	

\* Excludes crystal.

### Miscellaneous

Crystal XLI — Style E 450 kc/s  $\pm 0.5\%$  : 6240P.  
 Glass window : 5847P.  
 Control knobs — small : 5816P.  
 Control knobs — large : 5817P.  
 Control knobs — chrome : 5780P.  
 Dial lamps : 3131P.  
 BFO Unit : D2891.